

# FLEX TRACK

## *Features:*

- Flex Track is a light weight portable CNC drilling machine
- Flexible rails adhere to contoured surfaces using vacuum cups
- The Flex Track utilizes features in the structure to orient 2D part programs



Drilling accurate holes is important in all arenas of manufacturing and assembly. Current lean operations demand a new approach to cutting costs and staying flexible, while staying proficient at demanding jobs.

Lightweight portable automated drilling machines are now finding themselves competing with large machine tools drilling complex structures.

Flex Track uses a flexible primary axis coupled to the airframe by multiple vacuum cups. This support eliminates the need for a secondary machine tool frame dedicated to supporting the Flex Track. The flexibility of this axis also allows for the discrete elimination of an axis of rotation by allowing the machine to follow the contour of the structure.

Simplifying drilling by treating large structures as locally flat and directly coupling a machine to the surface allows small machines to compete. The result with Flex Track is a production machine tool with unlimited applications.



Mukilteo, WA, USA • Melbourne, Australia • Hawarden, Deeside, UK • Filton, Bristol, UK

(425) 348-8090

[www.electroimpact.com](http://www.electroimpact.com)

## *Production Implementations:*

- F-15 Rear Fuselage
- 787 Production Wing
- 787 Vertical Fin
- 777 Aft Fuselage
- G650 Wing Splice
- Bombardier C-Series Wing
- A350 Demo Box
- 767 Aft Fuselage
- 787 Mid Body Fuselage
- Embraer 170,175,190,195 Laps
- 777 Forward Fuselage
- 777 Wing Panel Build

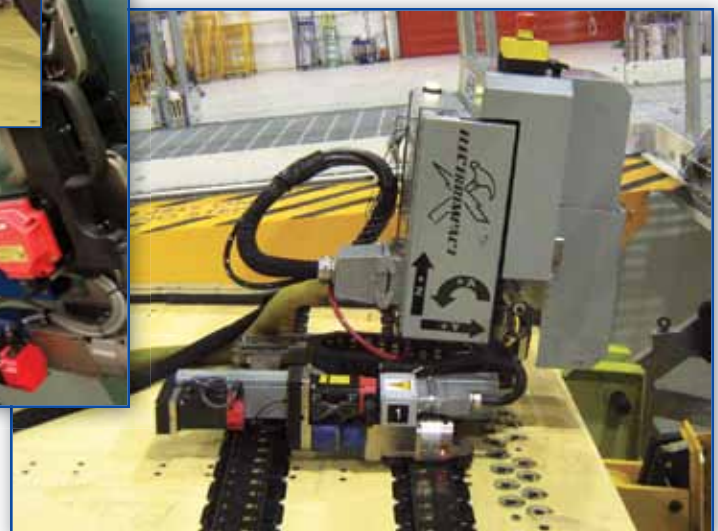
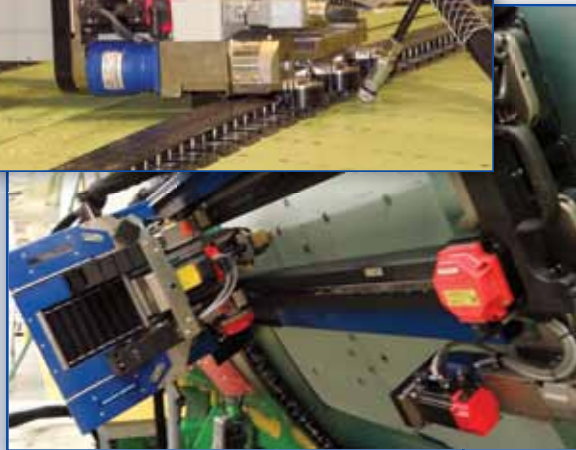

## *Typical Applications:*

- Wing Panel Splice, Rib Drilling
- Fuselage Circumferential Joints
- Longitudinal Fuselage Laps, Spar Drilling

# Wide Flex Track

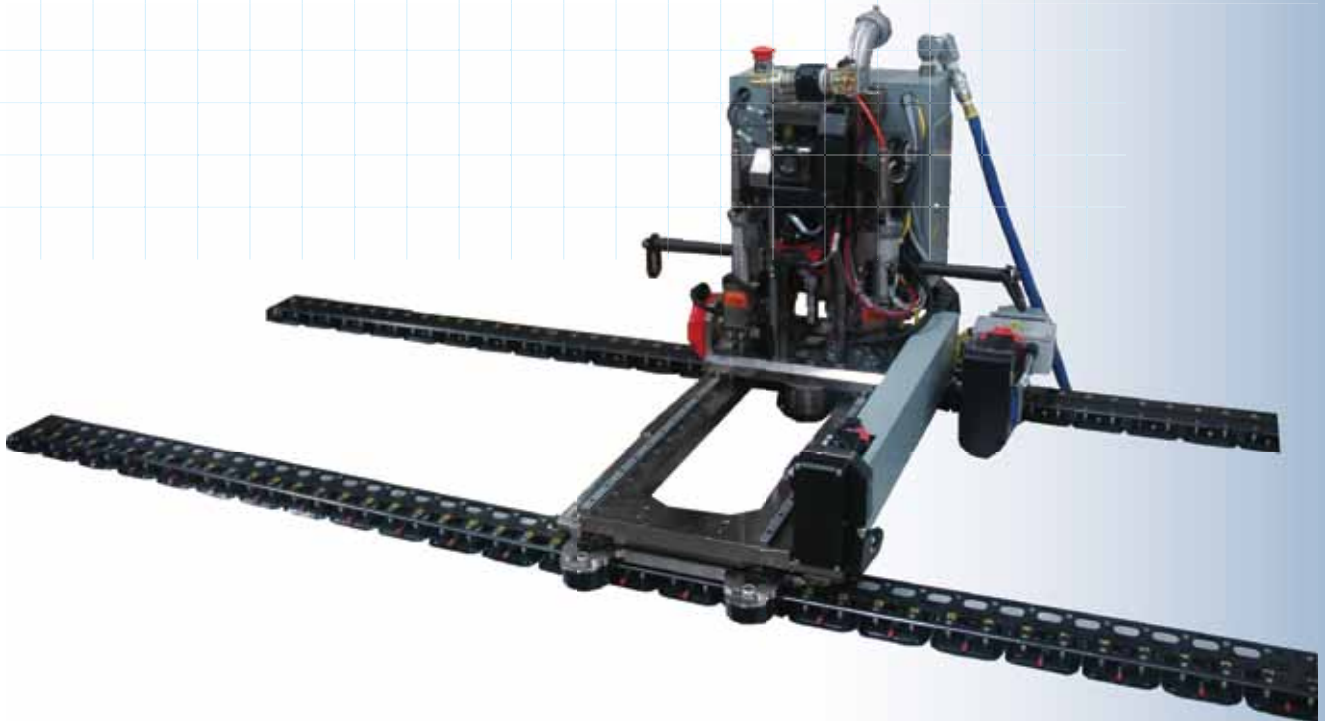

Wide Flex Tracks offer a light weight removable Drilling Head with coverage up to 18". The standard 4-Axis Wide Carriage Flex Track can be deployed on Fuselage Laps, Fuselage body panels, wing splices and many more applications.

A Rotational Axis A offers rotation about the flexible rails. Rotation is controlled by an actuator with secondary feedback on the pivot axis and commanded by normality sensors in the nosepiece contacting the work surface.

Standard staged-at-clamp drilling with thermally isolated secondary feedback offers accurate one step drilling and countersinking on even loosely tooled parts. Spliceable rails allow multiple sections of Flex Track rail to be connected allowing for greater coverage.

# Offset Flex Track

Offset Flex Track enables drilling at panel edges.

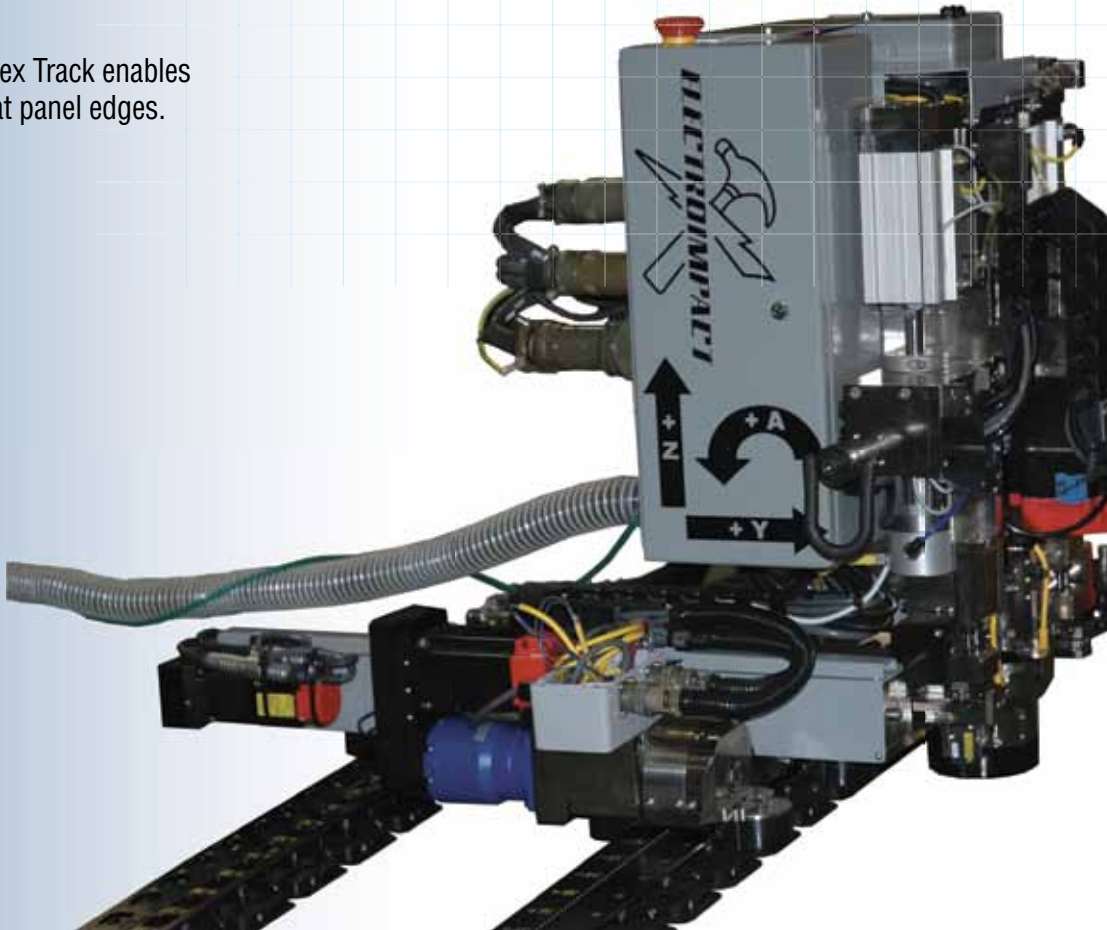

Panel edges, Door Surrounds, Lap joins, or holes just too close for a standard Flex Track to drill may require an Offset Flex Track. Just like the wide carriage, the offset offers an A-Axis Correction with Normality Sensing.

The Offset feature allows for 4"-6" of Offset drilling as well as between-the-track drilling. Currently Electroimpact offers a high-torque Offset drill with capacity up to 5/8" diameter, weighing 125 lbs. Also a lightweight design exists with capacity to 3/8" weighing only 95 lbs.

# Extra Wide Flex Tracks

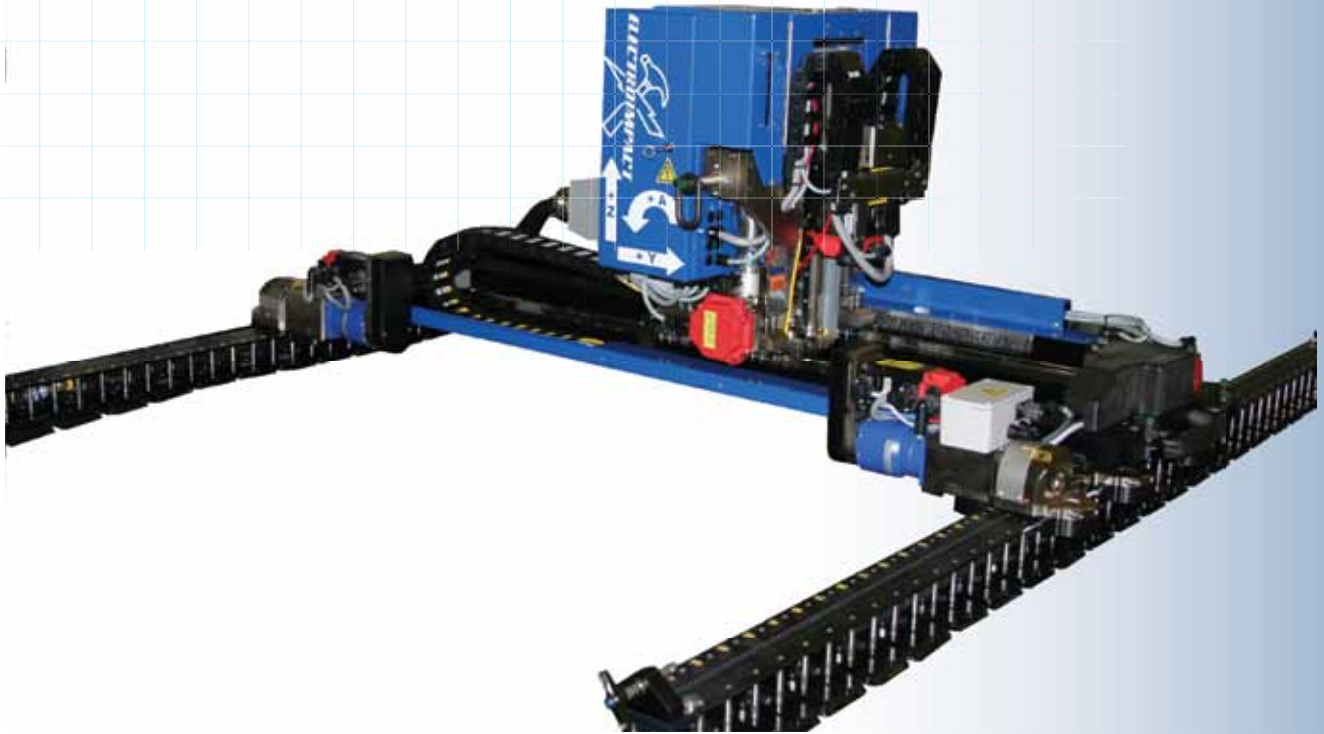

Traditionally, circumferential drilling is difficult to automate due to the large machine needed to traverse the expanse of the fuselage. Existing fuselage assembly jigs were not designed to accept a large piece of automation.

Flex Track attaches directly to the fuselage and uses the massive parts it's drilling as the primary machine base. Flex Track rails splice together indefinitely and small local transformations eliminate the need for 'global' accuracy. Track designs use compressed air and hundreds of venturi pumps to generate vacuum.

A Fanuc 31i CNC is utilized to control the synchronous track drive motors and the total of seven axes needed for a fuselage Flex Track.

# Multi-Function Flex Track

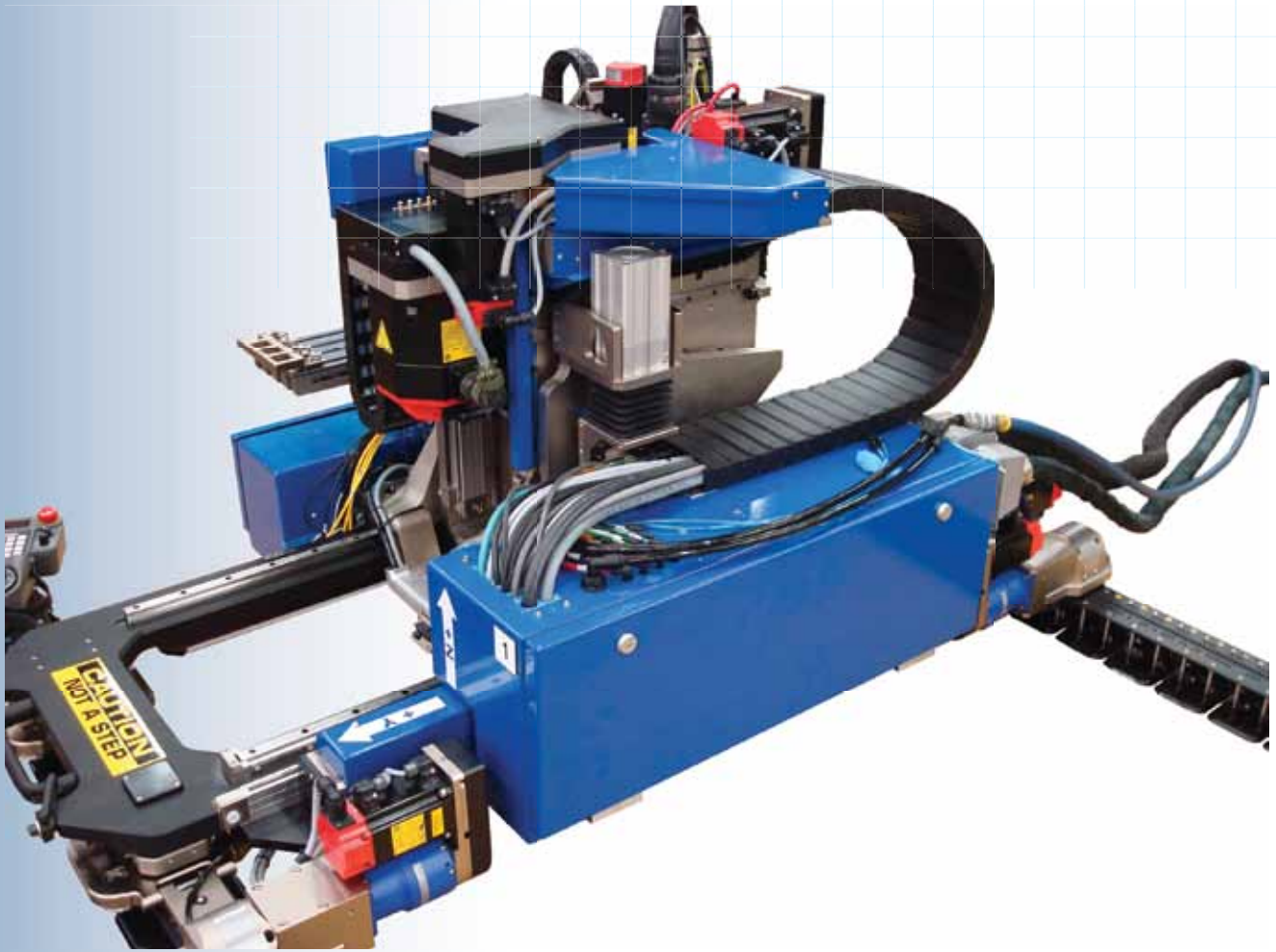

A Multi-Function Flex Track drills large holes, finds Datum features, performs all hole quality checks, and carries and installs temporary fasteners.

Additional features include Balluff RFID for fast and accurate tool changes, removable nosepiece with integrated laser edge finder, broken drill bit detection, onboard toolpoint camera, work area lighting, and both flood and through-the-bit Lubrication.

## *Flex Track **Standard** and **Optional** Features:*

- Multi-axis positioning with 3-6 axis varieties
- Hole drilling to 5/8" diameter
- Composite/Titanium stack drilling capability
- Normality sensor system with +/- 0.03 degree accuracy
- Flood coolant with 99% coolant recovery
- Integrated chip management system
- Track weight: 30 lbs per 72" section
- Fanuc pendant control
- Fanuc Picture Graphical user interface
- Vision systems
- Catia V5 Offline programming with flat pattern generation
- Multiple position operation including vertical surfaces and upside-down on horizontal surfaces
- CE marking
- Offset fixed vision systems, on axis removable vision systems, laser alignment sensors, and wireless touch probing
- Load Cell
- Balluff RFID
- Hole Probing
- Fastener Installation
- Broken bit detection





HAWDE CNC drilling machine travels up and down elevators and moves between jigs



Wing panel machine drills holes, applies sealant, inserts fasteners, shaves



Flextrack CNC ultralight drilling machine adapts to curved surfaces



Electroimpact end effector on KUKA robot enables aircraft quality hole drilling



Twin machines laying tow simultaneously



EI Metrology equipment includes the FARO ION, LEICA AT-401 and LEICA AT-901 laser trackers

### ▶ *Aerospace Tooling*

Stage 0 (wing panel assembly) jigs  
Stage 1 (wing major) jigs  
Small aircraft assembly tooling  
Fuselage and wing join systems  
Portable tooling

### ▶ *Assembly Automation (Complete one-up assembly)*

Ti/Al/Composite drilling machines  
Rivet/bolt insertion machines  
Multi-axis CNC machines  
Custom machines

### ▶ *Robotics*

Robotic multi-function end effectors  
Patent pending accurate robot technology

### ▶ *Space and Defense*

Ground support equipment  
Satellite dollies  
Antenna positioners  
Shipping containers

### ▶ *Services*

Engineering  
Oversize machining  
Build to print services

### ▶ *Large Scale 3D Metrology*

### ▶ *Automated Fiber*

*Placement Machines*  
Modular, rapid change-out heads  
Multiple tow widths from a single machine  
Post mill and gantry designs  
Fully bi-directional operation  
Short course high performance optimized



Mukilteo, WA, USA  
Melbourne, Australia

Hawarden, Deeside, UK  
Filton, Bristol, UK

(425) 348-8090  
[www.electroimpact.com](http://www.electroimpact.com)

Peter Zieve, *President* (peterz@electroimpact.com)  
John Hartmann, *Vice President* (johnh@electroimpact.com)